

Hardware List:

- Beam Bolts: (2 each)- $\frac{1}{2}$ "x6-1/2" Hex Bolts, $\frac{1}{2}$ " Reg. Hex Nuts
- (4) - $\frac{1}{2}$ " Fender Washers
- 1x8 to 2x8 Connections: 2-3/4" Construction Screws (predrill)
- Other Connections: 1-1/2" Construction Screws (predrill)
- Handles: (2) 3-1/2" Folding Pull Handles w/Mounting
- Plates w/(Bolts & Stopnuts to fit handles - $\frac{3}{4}$ " or 1" long bolts)
- Hinges: Machine Screws/washers/stop nuts for hinges (to fit)
- Cover Latching: (3) - 1/4-20 x 2" Hanger Bolts
- 1/4-20 wingnuts and washers (3 each)
- Machine Screws ($\frac{3}{4}$ " long x dia to fit hinges) + Nuts + Washers

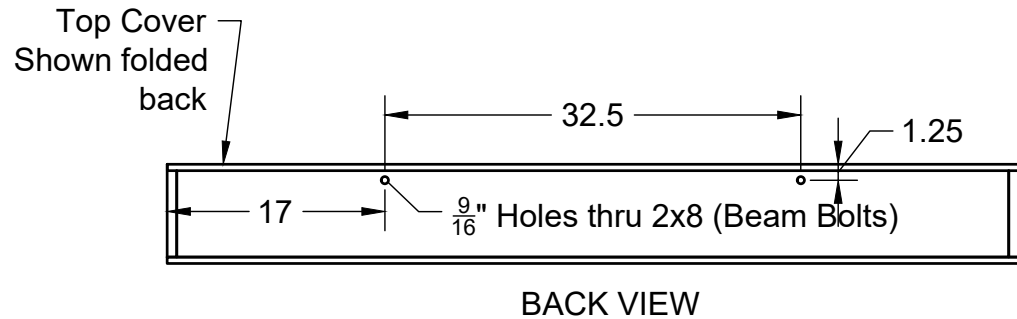

**5 ft Scraper (Single) Blade Box Plan
Centerville Curling Club - Wisconsin**